

**Ceiling unit**  
**Pure'line 90 cm (without motor)**  
**Stainless steel**

EAN 5414425116560

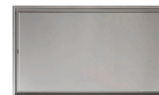

### Functions & features

▪ Control method	Push buttons + Remote control
▪ Number of speeds	3 + power
▪ Automatic Power revert (minutes)	6
▪ Motor	Without
▪ Sound absorber	Integrated
▪ InTouch function	Standard
▪ Auto stop	▪
▪ Delayed switch off (minutes)	10/30
▪ Number of grease filters	2
▪ Grease filter	6830020
▪ Grease filter cleaning indication	▪
▪ Recirculation filter cleaning indication	-

### Dimensions

▪ Product dimensions (WxDxH) (mm)	868 x 508 x 81
▪ Height incl. mounting clamps (without motorbox) (mm)	133
▪ Width flange (mm)	15
▪ Dimensions cut-out opening (WxD) (mm)	845 x 485
▪ Advised mounting height induction hobs (Hmin-Hmax) (mm)	600 - 1600
▪ Advised mounting height gas hobs (Hmin-Hmax) (mm)	650 - 1600
▪ Advised mounting height ceramic hobs (Hmin-Hmax) (mm)	600 - 1600
▪ Diameter outlet (mm)	150
▪ Position exhaust	Top

### Lighting

▪ Dimmable light	-
▪ Soft-ON/OFF	-
▪ External light connector	220-230V / max 300W / Not Dimmable

### Airflow and noise level

- Airflow (m<sup>3</sup>/h) measured according to
- Sound regulation according to

### Technical specifications

▪ Voltage (V)	220-230
▪ Frequency (Hz)	50
▪ Length power supply cord (m)	1,2
▪ Power consumption in stand-by-mode (Ps) (W)	0.29
▪ Net weight (kg)	16

1

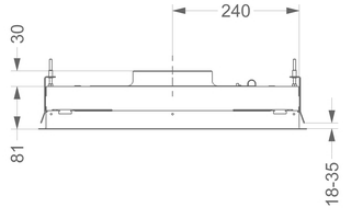

2

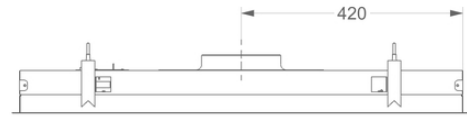

3

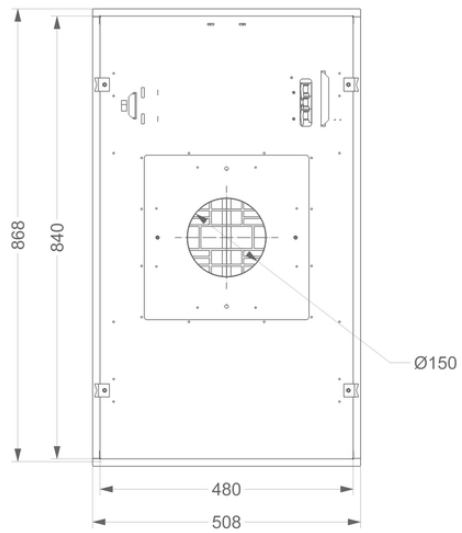

4

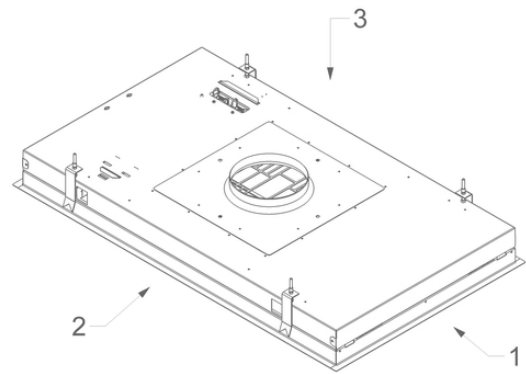

## Installation accessories

---

### Dissociated motor

- 445999
- 645999
- 745999
- 655999
- 755999

Separate motor outdoor wall installation

Flat roof motor 48,8 cm high, 790 m<sup>3</sup>/h

Flat roof motor 48,8 cm high, 1.150 m<sup>3</sup>/h

Flat roof motor with silencer 78,4 cm high, 790 m<sup>3</sup>/h

Flat roof motor with silencer 78,4 cm high, 1.150 m<sup>3</sup>/h

### Extension cable

- 7000092

Extension cable 5 m

## Accessories

---

### Adapter for limited installation height



6830052

Adapter for limited installation height 17,3 cm

### Control kit



990030

Control kit for external lighting or valve

